

PRO-DIPX 80/88-...

50 W Diplexer for the 0 - 80 MHz and 88 - 960 MHz Ranges

- > Diplexer for combining or splitting the two ranges 0 - 80 MHz and 88 - 960 MHz.
- > Chebychev design ensures very high isolation across the whole pass ranges.

DESCRIPTION

- > High power handling capability.
- > Low insertion loss.
- > Low weight.
- > Wide temperature range.
- > Milled aluminium box ensures extraordinarily high mechanical strength.
- > PRO-DIPX 80/88-... is coated with black vinyl to prevent corrosion.
- > Available with N-, SMA-, TNC- or BNC-female connector types.

ORDERING DESIGNATIONS

TYPE	PRODUCT NO.
PRO-DIPX 80/88-N(f)	200001993
PRO-DIPX 80/88-SMA(f)	200002669
PRO-DIPX 80/88-TNC(f)	200002670
PRO-DIPX 80/88-BNC(f)	200002671



SPECIFICATIONS

ELECTRICAL	
MODEL	PRO-DIPX 80/88-...
FREQUENCY	COM-LOW port: 0 - 80 MHz COM-HIGH port: 88 - 960 MHz
MAX. RF POWER	50W CW simultaneously on both HIGH and LOW port
INSERTION LOSS	0 - 80 MHz: ≤ 1.2 dB 88 - 960 MHz: ≤ 1.0 dB
ISOLATION	LOW to HIGH port: ≥ 40 dB
IMPEDANCE	Nom. 50 Ω
SWR	Max. 1.5:1 on all ports

MECHANICAL	
TEMP. RANGE *	-40° C to +60° C
CONNECTORS	N-, SMA-, TNC- or BNC-female
IP RATING	IP62
DIMENSIONS (L x W x H)	133 x 80 x 31 mm / 5.24 x 3.15 / 1.22 in. (incl. connectors and flanges)
WEIGHT	Approx. 380 g / 0.84 lb.
MOUNTING	$\varnothing 4.3$ mm / $\varnothing 0.17$ in. (4 holes)

MOUNTING DETAILS

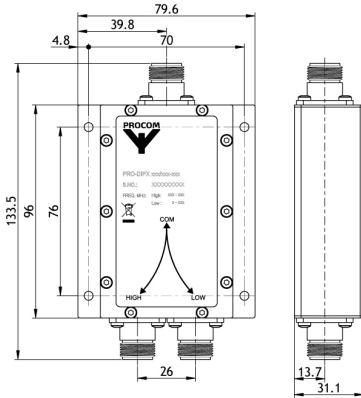

TYPICAL RESPONSE CURVES

INSERTION LOSS [dB]

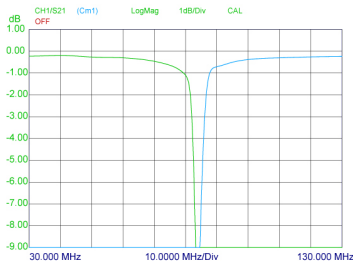

PORT ATTENUATION [dB]

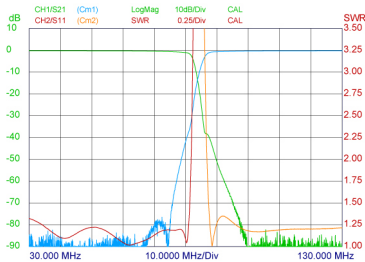

The PRO-DIPX 80/88-... makes it possible to use only one antenna for the operation of two transceivers (one in each range). See the figure below. The antenna must be a dual-frequency antenna, i.e. it must be resonant on the actual frequencies in the two bands.

The transceivers may be used independently and will have no degrading influence on each other. Typically, the diplexer is installed next to the transceivers and only one cable is used between the diplexer and the antenna. The diplexer is suitable both for base station and mobile use.

The main tasks of the diplexer are to protect the individual receiver input from being destroyed by the transceiver in the contrary band and to ensure a low-loss path between the transceiver and the antenna which is not loaded by the other branch.

The diplexer can be operated together with any set of transceivers operating within the 0 - 80 MHz and 88 - 960 MHz frequency bands.

